

PART A INVITATION TO BID

YOU ARE HEREBY INVITED TO BID FOR REQUIREMENTS OF THE (NAME OF DEPARTMENT/ PUBLIC ENTITY)					
BID NUMBER:	IPID05/2023/24	CLOSING DATE: 15 NOVEMBER 2023	CLOSING TIME:	11:00	
DESCRIPTION	INVITATION TO SUBMIT PROPOSAL FOR THE APPOINTMENT OF SERVICE PROVIDER TO SUPPLY, DELIVER, INSTAL, TEST, COMMISSION AND MAINTAIN THE X-RAY MACHINE FOR A PERIOD OF THREE (3) YEARS AT INDEPENDENT POLICE INVESTIGATIVE DIRECTORATE (IPI) 'S OFFICE SITUATED AT 473 BENSTRA BUILDING, ACARDIA				
BID RESPONSE DOCUMENTS MAY BE DEPOSITED IN THE BID BOX SITUATED AT (STREET ADDRESS)					
GROUND FLOOR					
BENSTRA BUILDING					
473 STANZA BOPAPE STREET					
ACARDIA, PRETORIA					
BIDDING PROCEDURE ENQUIRIES MAY BE DIRECTED TO			TECHNICAL ENQUIRIES MAY BE DIRECTED TO:		
CONTACT PERSON	MS F MASEKO / MR M GQALANE		CONTACT PERSON	MR T MATHIVHA	
TELEPHONE NUMBER	012 399 0095 / 012 399 0106		TELEPHONE NUMBER	012 399 0060	
FACSIMILE NUMBER	N/A		FACSIMILE NUMBER	N/A	
E-MAIL ADDRESS	fmaseko@ipid.gov.za / mgqalane@ipid.gov.za		E-MAIL ADDRESS	Tmathivha@ipid.gov.za	
SUPPLIER INFORMATION					
NAME OF BIDDER					
POSTAL ADDRESS					
STREET ADDRESS					
TELEPHONE NUMBER	CODE		NUMBER		
CELLPHONE NUMBER					
FACSIMILE NUMBER	CODE		NUMBER		
E-MAIL ADDRESS					
VAT REGISTRATION NUMBER					
SUPPLIER COMPLIANCE STATUS	TAX COMPLIANCE SYSTEM PIN:		OR	CENTRAL SUPPLIER DATABASE No:	MAAA
ARE YOU THE ACCREDITED REPRESENTATIVE IN SOUTH AFRICA FOR THE GOODS /SERVICES OFFERED?	<input type="checkbox"/> Yes <input type="checkbox"/> No [IF YES ENCLOSE PROOF]		ARE YOU A FOREIGN BASED SUPPLIER FOR THE GOODS /SERVICES OFFERED?	<input type="checkbox"/> Yes <input type="checkbox"/> No [IF YES, ANSWER THE QUESTIONNAIRE BELOW]	
QUESTIONNAIRE TO BIDDING FOREIGN SUPPLIERS					
IS THE ENTITY A RESIDENT OF THE REPUBLIC OF SOUTH AFRICA (RSA)?				<input type="checkbox"/> YES <input type="checkbox"/> NO	
DOES THE ENTITY HAVE A BRANCH IN THE RSA?				<input type="checkbox"/> YES <input type="checkbox"/> NO	
DOES THE ENTITY HAVE A PERMANENT ESTABLISHMENT IN THE RSA?				<input type="checkbox"/> YES <input type="checkbox"/> NO	
DOES THE ENTITY HAVE ANY SOURCE OF INCOME IN THE RSA?				<input type="checkbox"/> YES <input type="checkbox"/> NO	
IS THE ENTITY LIABLE IN THE RSA FOR ANY FORM OF TAXATION?				<input type="checkbox"/> YES <input type="checkbox"/> NO	
IF THE ANSWER IS "NO" TO ALL OF THE ABOVE, THEN IT IS NOT A REQUIREMENT TO REGISTER FOR A TAX COMPLIANCE STATUS SYSTEM PIN CODE FROM THE SOUTH AFRICAN REVENUE SERVICE (SARS) AND IF NOT REGISTER AS PER 2.3 BELOW.					

**PART B
TERMS AND CONDITIONS FOR BIDDING**

1. BID SUBMISSION:

- 1.1. BIDS MUST BE DELIVERED BY THE STIPULATED TIME TO THE CORRECT ADDRESS. LATE BIDS WILL NOT BE ACCEPTED FOR CONSIDERATION.
- 1.2. **ALL BIDS MUST BE SUBMITTED ON THE OFFICIAL FORMS PROVIDED (NOT TO BE RE-TYPED) OR IN THE MANNER PRESCRIBED IN THE BID DOCUMENT.**
- 1.3. THIS BID IS SUBJECT TO THE PREFERENTIAL PROCUREMENT POLICY FRAMEWORK ACT, 2000 AND THE PREFERENTIAL PROCUREMENT REGULATIONS, THE GENERAL CONDITIONS OF CONTRACT (GCC) AND, IF APPLICABLE, ANY OTHER SPECIAL CONDITIONS OF CONTRACT.
- 1.4. **THE SUCCESSFUL BIDDER WILL BE REQUIRED TO FILL IN AND SIGN A WRITTEN CONTRACT FORM (SBD7).**

2. TAX COMPLIANCE REQUIREMENTS

- 2.1 BIDDERS MUST ENSURE COMPLIANCE WITH THEIR TAX OBLIGATIONS.
- 2.2 BIDDERS ARE REQUIRED TO SUBMIT THEIR UNIQUE PERSONAL IDENTIFICATION NUMBER (PIN) ISSUED BY SARS TO ENABLE THE ORGAN OF STATE TO VERIFY THE TAXPAYER'S PROFILE AND TAX STATUS.
- 2.3 APPLICATION FOR TAX COMPLIANCE STATUS (TCS) PIN MAY BE MADE VIA E-FILING THROUGH THE SARS WEBSITE WWW.SARS.GOV.ZA.
- 2.4 BIDDERS MAY ALSO SUBMIT A PRINTED TCS CERTIFICATE TOGETHER WITH THE BID.
- 2.5 IN BIDS WHERE CONSORTIA / JOINT VENTURES / SUB-CONTRACTORS ARE INVOLVED; EACH PARTY MUST SUBMIT A SEPARATE TCS CERTIFICATE / PIN / CSD NUMBER.
- 2.6 WHERE NO TCS PIN IS AVAILABLE BUT THE BIDDER IS REGISTERED ON THE CENTRAL SUPPLIER DATABASE (CSD), A CSD NUMBER MUST BE PROVIDED.
- 2.7 NO BIDS WILL BE CONSIDERED FROM PERSONS IN THE SERVICE OF THE STATE, COMPANIES WITH DIRECTORS WHO ARE PERSONS IN THE SERVICE OF THE STATE, OR CLOSE CORPORATIONS WITH MEMBERS PERSONS IN THE SERVICE OF THE STATE."

NB: FAILURE TO PROVIDE / OR COMPLY WITH ANY OF THE ABOVE PARTICULARS MAY RENDER THE BID INVALID.

SIGNATURE OF BIDDER:

CAPACITY UNDER WHICH THIS BID IS SIGNED:
(Proof of authority must be submitted e.g. company resolution)

DATE:

**PRICING SCHEDULE – FIRM PRICES
(PURCHASES)**

NOTE: ONLY FIRM PRICES WILL BE ACCEPTED. NON-FIRM PRICES (INCLUDING PRICES SUBJECT TO RATES OF EXCHANGE VARIATIONS) WILL NOT BE CONSIDERED

IN CASES WHERE DIFFERENT DELIVERY POINTS INFLUENCE THE PRICING, A SEPARATE PRICING SCHEDULE MUST BE SUBMITTED FOR EACH DELIVERY POINT

Name of bidder.....	Bid number IPID05/2023/24
Closing Time 11:00	Closing date: 15 November 2023

OFFER TO BE VALID FOR 120 DAYS FROM THE CLOSING DATE OF BID.

ITEM NO.	QUANTITY	DESCRIPTION	BID PRICE IN RSA CURRENCY ** (ALL APPLICABLE TAXES INCLUDED)
----------	----------	-------------	---

INVITATION TO SUBMIT PROPOSAL FOR THE APPOINTMENT OF A SERVICE PROVIDER TO SUPPLY, DELIVER, INSTALL, TEST, COMMISSION AND MAINTAIN THE X-RAY MACHINE FOR A PERIOD OF THREE (3) YEARS AT INDEPENDENT POLICE INVESTIGATIVE DIRECTORATE (IPID) 'S OFFICE SITUATED AT 473 BENSTRA BUILDING, ACARDIA

- Required by: INDEPENDENT POLICE INVESTIGATIVE DIRECTORATE
- At: BENSTRA BUILDING
473 STANZA BOPAPE STREET
ACARDIA
PRETORIA
- Brand and model
- Country of origin
- Does the offer comply with the specification(s)? *YES/NO
- If not to specification, indicate deviation(s)
- Period required for delivery
*Delivery: Firm/not firm
- Delivery basis

Note: All delivery costs must be included in the bid price, for delivery at the prescribed destination.

** "all applicable taxes" includes value- added tax, pay as you earn, income tax, unemployment insurance fund contributions and skills development levies.

*Delete if not applicable

BIDDER'S DISCLOSURE

1. PURPOSE OF THE FORM

Any person (natural or juristic) may make an offer or offers in terms of this invitation to bid. In line with the principles of transparency, accountability, impartiality, and ethics as enshrined in the Constitution of the Republic of South Africa and further expressed in various pieces of legislation, it is required for the bidder to make this declaration in respect of the details required hereunder.

Where a person/s are listed in the Register for Tender Defaulters and / or the List of Restricted Suppliers, that person will automatically be disqualified from the bid process.

2. Bidder's declaration

2.1 Is the bidder, or any of its directors / trustees / shareholders / members / partners or any person having a controlling interest¹ in the enterprise, employed by the state? **YES/NO**

2.1.1 If so, furnish particulars of the names, individual identity numbers, and, if applicable, state employee numbers of sole proprietor/ directors / trustees / shareholders / members/ partners or any person having a controlling interest in the enterprise, in table below.

Full Name	Identity Number	Name of State institution

2.2 Do you, or any person connected with the bidder, have a relationship

¹ the power, by one person or a group of persons holding the majority of the equity of an enterprise, alternatively, the person/s having the deciding vote or power to influence or to direct the course and decisions of the enterprise.

with any person who is employed by the procuring institution? **YES/NO**

2.2.1 If so, furnish particulars:

.....
.....

2.3 Does the bidder or any of its directors / trustees / shareholders / members / partners or any person having a controlling interest in the enterprise have any interest in any other related enterprise whether or not they are bidding for this contract? **YES/NO**

2.3.1 If so, furnish particulars:

.....
.....

3 DECLARATION

I, _____ the _____ undersigned, (name)..... in submitting the accompanying bid, do hereby make the following statements that I certify to be true and complete in every respect:

- 3.1 I have read and I understand the contents of this disclosure;
- 3.2 I understand that the accompanying bid will be disqualified if this disclosure is found not to be true and complete in every respect;
- 3.3 The bidder has arrived at the accompanying bid independently from, and without consultation, communication, agreement or arrangement with any competitor. However, communication between partners in a joint venture or consortium² will not be construed as collusive bidding.
- 3.4 In addition, there have been no consultations, communications, agreements or arrangements with any competitor regarding the quality, quantity, specifications, prices, including methods, factors or formulas used to calculate prices, market allocation, the intention or decision to submit or not to submit the bid, bidding with the intention not to win the bid and conditions or delivery particulars of the products or services to which this bid invitation relates.
- 3.4 The terms of the accompanying bid have not been, and will not be, disclosed by the bidder, directly or indirectly, to any competitor, prior to the date and time of the official bid opening or of the awarding of the contract.
- 3.5 There have been no consultations, communications, agreements or arrangements made by the bidder with any official of the procuring

² Joint venture or Consortium means an association of persons for the purpose of combining their expertise, property, capital, efforts, skill and knowledge in an activity for the execution of a contract.

institution in relation to this procurement process prior to and during the bidding process except to provide clarification on the bid submitted where so required by the institution; and the bidder was not involved in the drafting of the specifications or terms of reference for this bid.

- 3.6 I am aware that, in addition and without prejudice to any other remedy provided to combat any restrictive practices related to bids and contracts, bids that are suspicious will be reported to the Competition Commission for investigation and possible imposition of administrative penalties in terms of section 59 of the Competition Act No 89 of 1998 and or may be reported to the National Prosecuting Authority (NPA) for criminal investigation and or may be restricted from conducting business with the public sector for a period not exceeding ten (10) years in terms of the Prevention and Combating of Corrupt Activities Act No 12 of 2004 or any other applicable legislation.

I CERTIFY THAT THE INFORMATION FURNISHED IN PARAGRAPHS 1, 2 and 3 ABOVE IS CORRECT.

I ACCEPT THAT THE STATE MAY REJECT THE BID OR ACT AGAINST ME IN TERMS OF PARAGRAPH 6 OF PFMA SCM INSTRUCTION 03 OF 2021/22 ON PREVENTING AND COMBATING ABUSE IN THE SUPPLY CHAIN MANAGEMENT SYSTEM SHOULD THIS DECLARATION PROVE TO BE FALSE.

..... Signature Date
..... Position Name of bidder

**PREFERENCE POINTS CLAIM FORM IN TERMS OF THE PREFERENTIAL
PROCUREMENT REGULATIONS 2022**

This preference form must form part of all tenders invited. It contains general information and serves as a claim form for preference points for specific goals.

NB: BEFORE COMPLETING THIS FORM, TENDERERS MUST STUDY THE GENERAL CONDITIONS, DEFINITIONS AND DIRECTIVES APPLICABLE IN RESPECT OF THE TENDER AND PREFERENTIAL PROCUREMENT REGULATIONS, 2022

1. GENERAL CONDITIONS

1.1 The following preference point systems are applicable to invitations to tender:

- the 80/20 system for requirements with a Rand value of up to R50 000 000 (all applicable taxes included); and
- the 90/10 system for requirements with a Rand value above R50 000 000 (all applicable taxes included).

1.2 To be completed by the organ of state

(delete whichever is not applicable for this tender).

- a) The applicable preference point system for this tender is the 80/20 preference point system.
- b) 80/20 preference point system will be applicable in this tender. The lowest/ highest acceptable tender will be used to determine the accurate system once tenders are received.

1.3 Points for this tender (even in the case of a tender for income-generating contracts) shall be awarded for:

- (a) Price; and
- (b) Specific Goals.

1.4 To be completed by the organ of state:

The maximum points for this tender are allocated as follows:

	POINTS
PRICE	80
SPECIFIC GOALS	20
Total points for Price and SPECIFIC GOALS	100

1.5 Failure on the part of a tenderer to submit proof or documentation required in terms of this tender to claim points for specific goals with the tender, will be interpreted to mean that preference points for specific goals are not claimed.

- 1.6 The organ of state reserves the right to require of a tenderer, either before a tender is adjudicated or at any time subsequently, to substantiate any claim in regard to preferences, in any manner required by the organ of state.

2. DEFINITIONS

- (a) **“tender”** means a written offer in the form determined by an organ of state in response to an invitation to provide goods or services through price quotations, competitive tendering process or any other method envisaged in legislation;
- (b) **“price”** means an amount of money tendered for goods or services, and includes all applicable taxes less all unconditional discounts;
- (c) **“rand value”** means the total estimated value of a contract in Rand, calculated at the time of bid invitation, and includes all applicable taxes;
- (d) **“tender for income-generating contracts”** means a written offer in the form determined by an organ of state in response to an invitation for the origination of income-generating contracts through any method envisaged in legislation that will result in a legal agreement between the organ of state and a third party that produces revenue for the organ of state, and includes, but is not limited to, leasing and disposal of assets and concession contracts, excluding direct sales and disposal of assets through public auctions; and
- (e) **“the Act”** means the Preferential Procurement Policy Framework Act, 2000 (Act No. 5 of 2000).

3. FORMULAE FOR PROCUREMENT OF GOODS AND SERVICES

3.1. POINTS AWARDED FOR PRICE

3.1.1 THE 80/20 OR 90/10 PREFERENCE POINT SYSTEMS

A maximum of 80 or 90 points is allocated for price on the following basis:

$$Ps = 80 \left(1 - \frac{Pt - Pmin}{Pmin} \right) \quad \text{or} \quad Ps = 90 \left(1 - \frac{Pt - Pmin}{Pmin} \right)$$

Where

Ps = Points scored for price of tender under consideration

Pt = Price of tender under consideration

Pmin = Price of lowest acceptable tender

3.2. FORMULAE FOR DISPOSAL OR LEASING OF STATE ASSETS AND INCOME GENERATING PROCUREMENT

3.2.1. POINTS AWARDED FOR PRICE

A maximum of 80 or 90 points is allocated for price on the following basis:

$$Ps = 80 \left(1 + \frac{Pt - P_{max}}{P_{max}} \right) \text{ or } Ps = 90 \left(1 + \frac{Pt - P_{max}}{P_{max}} \right)$$

Where

- Ps = Points scored for price of tender under consideration
Pt = Price of tender under consideration
Pmax = Price of highest acceptable tender

4. POINTS AWARDED FOR SPECIFIC GOALS

- 4.1. In terms of Regulation 4(2); 5(2); 6(2) and 7(2) of the Preferential Procurement Regulations, preference points must be awarded for specific goals stated in the tender. For the purposes of this tender the tenderer will be allocated points based on the goals stated in table 1 below as may be supported by proof/ documentation stated in the conditions of this tender:
- 4.2. In cases where organs of state intend to use Regulation 3(2) of the Regulations, which states that, if it is unclear whether the 80/20 or 90/10 preference point system applies, an organ of state must, in the tender documents, stipulate in the case of—
- (a) an invitation for tender for income-generating contracts, that either the 80/20 or 90/10 preference point system will apply and that the highest acceptable tender will be used to determine the applicable preference point system; or
 - (b) any other invitation for tender, that either the 80/20 or 90/10 preference point system will apply and that the lowest acceptable tender will be used to determine the applicable preference point system,
- then the organ of state must indicate the points allocated for specific goals for both the 90/10 and 80/20 preference point system.

Table 1: Specific goals for the tender and points claimed are indicated per the table below.

(Note to organs of state: Where either the 90/10 or 80/20 preference point system is applicable, corresponding points must also be indicated as such.)

Note to tenderers: The tenderer must indicate how they claim points for each preference point system.)

The specific goals allocated points in terms of this tender	Number of points allocated (90/10 system) (To be completed by the organ of state)	Number of points allocated (80/20 system) (To be completed by the organ of state)	Number of points claimed (90/10 system) (To be completed by the tenderer)	Number of points claimed (80/20 system) (To be completed by the tenderer)
Enterprises with ownership of 51% or more by person/s who are Black		8		
Enterprises with ownership of 51% or more by person/s who are Women		8		
Enterprises with ownership of 51% or more by person/s who are Youth		2		
Enterprises with ownership of 51% or more by person/s with Disability		2		

DECLARATION WITH REGARD TO COMPANY/FIRM

4.3. Name of company/firm.....

4.4. Company registration number:

4.5. TYPE OF COMPANY/ FIRM

- Partnership/Joint Venture / Consortium
- One-person business/sole propriety
- Close corporation
- Public Company
- Personal Liability Company
- (Pty) Limited
- Non-Profit Company
- State Owned Company

[TICK APPLICABLE BOX]

4.6. I, the undersigned, who is duly authorised to do so on behalf of the company/firm, certify that the points claimed, based on the specific goals as advised in the tender, qualifies the company/ firm for the preference(s) shown and I acknowledge that:

- i) The information furnished is true and correct;
- ii) The preference points claimed are in accordance with the General Conditions as indicated in paragraph 1 of this form;
- iii) In the event of a contract being awarded as a result of points claimed as shown in paragraphs 1.4 and 4.2, the contractor may be required to furnish documentary proof to the satisfaction of the organ of state that the claims are correct;
- iv) If the specific goals have been claimed or obtained on a fraudulent basis or any of the conditions of contract have not been fulfilled, the organ of state may, in addition to any other remedy it may have –
 - (a) disqualify the person from the tendering process;
 - (b) recover costs, losses or damages it has incurred or suffered as a result of that person’s conduct;
 - (c) cancel the contract and claim any damages which it has suffered as a result of having to make less favourable arrangements due to such cancellation;
 - (d) recommend that the tenderer or contractor, its shareholders and directors, or only the shareholders and directors who acted on a fraudulent basis, be restricted from obtaining business from any organ of state for a period not exceeding 10 years, after the *audi alteram partem* (hear the other side) rule has been applied; and
 - (e) forward the matter for criminal prosecution, if deemed necessary.

.....	
SIGNATURE(S) OF TENDERER(S)	
SURNAME AND NAME:
DATE:
ADDRESS:



independent police investigative directorate

Department.
Independent Police Investigative Directorate
REPUBLIC OF SOUTH AFRICA

SPECIFICATION FOR X-RAY MACHINES AND MAINTENANCE

THE APPOINTMENT OF A SERVICE PROVIDER TO SUPPLY, DELIVER, INSTALL, TEST, COMMISSION AND MAINTAIN THE X- RAY MACHINES FOR A PERIOD OF THREE (3) YEARS, AT IPID'S OFFICE SITUATED AT 473 BENSTRA BUILDING, ARCADIA.

1. Purpose

The intention of IPID is to appoint a Service Provider to supply, deliver, install, test, commission, and maintain a Security X-ray scanner at National office.

2. Background

The aim of the Department is to ensure an Independent oversight over the South African Police Service (SAPS) and the Municipality Police Service (MPS), and to conduct independent and impartial investigations of identified criminal offences allegedly committed by members of the SAPS and the MPS, and make appropriate recommendations.

The Security X-ray machine will assist the Department to improve the security measures by:

- a) Complying with the provision of Section 2(2), under which the furnishing of information, identification, declarations concerning hazardous objects and the of any suitcase, briefcase, handbag, bag, etc.
- b) To enforce the provision of the Control of Access to Public Premises and Vehicles Act (Act53 of 1985) for the purpose of safeguarding buildings or premises occupied or used by of under the control of government departments, in line with Section 2(2) (a), (b) and (c) of the Control of access to Public Premises and Vehicles Act No.53 of 1985.
- c) Control access to a building or part of the building where security officials identify and control. Enhance support of the security personnel. Performance in conforming to Local and International Security Standards.

3. Scope of work

- a) The successful Bidder will be required to supply, install and maintain an x-ray machines as outlined.
- b) The required system will be installed at the basement and parking floor.
- c) The installed system should have the capability to record and produce the reports on all activities/ transactions that were done daily upon request.

SPECIFICATION FOR X-RAY MACHINES AND MAINTENANCE

G.S.N



independent police investigative directorate

Department:
Independent Police Investigative Directorate
REPUBLIC OF SOUTH AFRICA

- d) The preferred Contractor must provide training to IPID Officials in Security management after installation and commission of the machine.
- e) The preferred contractor must be able to dispatch a technician where challenges are encountered with the system within 8 hours of logging a call.
- f) The preferred Bidder should provide a 12 month guarantee period.

4. Maintenance of the system for a period of 3 years

4.1 Guarantee and Maintenance

- a) The successful service provider shall guarantee and service the complete unit for a period of twelve (12) months from the date of delivery to site, and successful commissioning of the unit.
- b) During the period of guarantee, the successful service provider shall, at his own expense, carry out all necessary repair work, including material and labour, (excluding work required due to damage by others) in order to maintain the unit in a working condition.
- c) The successful service provider shall, during the period of guarantee, repair the unit to the satisfaction of the Department, within 24 hours after he has been notified that the unit is not operating.
- d) After the lapse of the initial twelve-month period of servicing, the successful service provider will be required to enter into a service agreement with the Department, for a further period of three (3) years. This agreement may subsequently be renewed for yearly periods.
- e) Normal maintenance shall be provided between 08H00 and 17H00 Monday to Friday
- f) Maintenance during public holidays and weekends shall be classified as emergency and shall be treated as such
- g) Monitor and advise the Security Manager about any technical problem/s or a need to upgrade the system
- h) Major maintenance, shutting down and testing of all system should be done on weekends to avoid noise and disturbance of continuous service delivery of the Department.



independent police investigative directorate

Department
Independent Police Investigative Directorate
REPUBLIC OF SOUTH AFRICA

4.2 Security Application System

- The application system should support Windows platform preferable server version Windows 2010 server or higher.
- All necessary accessories should be provided to make the application system functional.
- Monitor all alerts from the application system (alarms, environmental, access violation etc.)
- All the application systems must be integrated.

4.3 Description and quantity of equipment.

All equipment and system installed must meet current industry standards and must be SABS/ICASA approved



ITEM	DESCRIPTION	QTY	PICTURE / DRAWING / NOTES
a)	X-ray Machines: <ul style="list-style-type: none">Penetration values must boast up to 38 mm of steel.High level Resolution (42AWG).2X - 64X zoomAutomatic Threat AlertHigh Density AlertOA - Operator AssistIA - Image Archiving 150,000 Images0.5 Meter Entry & Exit Roller ConveyorsOrganic, Inorganic and Trimat FeatureInverse, High Penetration, low Penetration and Pseudo FunctionArticle TraysHigh level radiation safetyKeyboard21.5-inch single LCD screen4-inch cameraFingerprint/Password login method	2	 <p><i>*Please note that the attached picture is for illustration purposes only.</i></p>

G.D.N

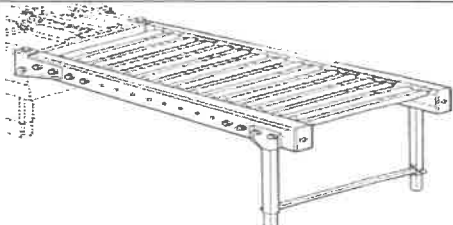

independent police investigative directorate

Department:
Independent Police Investigative Directorate
REPUBLIC OF SOUTH AFRICA

	<ul style="list-style-type: none">Security inspection networking and data storage for a period of six months		
b)	Accessories:		
	<ul style="list-style-type: none">0.5 Meter Entry & Exit Roller Conveyors;		<p><i>*Please note that the attached picture is for illustration purposes only.</i></p>
	<ul style="list-style-type: none">Article Trays (for normal hand luggage)		<p><i>*Please note that the attached picture is for illustration purposes only.</i></p>
	<ul style="list-style-type: none">Article Trays (for small items like cell phones)		
	<ul style="list-style-type: none">Remote Operator Table		Standard table size (940mm x 620mm)

7. MANDATORY REQUIREMENTS

7.1. Bidder (s) must submit the below documents:

- Maintenance program/ plan
- Evidence in support of Compliance with Occupational Health and Safety(OHS) (Act 85 of 1993)
- Valid PSIRA certificate
- Company Profile
- Reference letters from clients as well as an indication of experience with similar projects
- A license for the X-ray machine, issued in terms of the Hazardous Substances Act (Act 15 of 1973),
- CV's and ID copies of the service technicians registered to carry out the servicing of the X-ray machines in accordance with the requirements of the SABS.

GSDH



independent police investigative directorate

Department:
Independent Police Investigative Directorate
REPUBLIC OF SOUTH AFRICA

- (h) Submit a detailed breakdown of the budget per cost item (supply, installation and maintenance)
- (i) A detail broacher must be presented together with the tender documents.

NB: Any bidder who fails to comply with the above-mentioned mandatory requirements will be eliminated from the evaluation process and will not be considered for further evaluation

8. BID EVALUATION PROCESS

- (a) The evaluation criteria for the assessment of the proposals will be based on both qualitative and financial aspects of the proposal.
- (b) Bidders will be evaluated on three phases i.e., administrative requirements functionality and the price and HDI points.
- (c) The bidders that score 70 points or more will further be evaluated on price and specific goals in terms of the Preferential Procurement Policy Framework Act 5 of 2000 and Regulations of 2022.

9. Evaluation Criteria

9.1 Phase 1: Administrative Requirements

- a) Preferred bidder must be registered on CSD.
- b) Proof of CSD full report must be attached.
- c) Compliant Tax Status
- d) In order to advance the designated groups on the basis of Historically Disadvantaged Individuals (HDI), priority will be given to the following of which 51% are owned by: Blacks, Black Youth; Black Women; Black people with disabilities; Black People living in rural or underdeveloped areas; or townships; cooperatives owned by Black people; Black people who are Military Veterans;
- e) Company profile;
- f) SBD Forms fully completed and signed:
 - SBD 1 (Invitation to Bid)
 - SBD 3.1 Pricing schedule)
 - SBD 4 (Declaration of Interest)
 - SBD 6.1 (Preferential Procurement Regulations 2022)
- g) Original certified ID copies of all Directors not older than 6 months (A certified copy of a copy will not be accepted).
- h) Signatures and initialization on each page of the bid document.

N.B. Failure to comply with the above Administrative Requirements may result in disqualification.



independent police investigative directorate

Department.
Independent Police Investigative Directorate
REPUBLIC OF SOUTH AFRICA

9.2 Phase 2: Functionality

Relevant Skills and Experience and Industry Exposure:	Weight
<p>1. Track record and previous experience</p>	<p>The bidder's past experience in delivering projects of a similar nature and scale.</p> <ul style="list-style-type: none"> • Proposal should include a minimum of five (5) contactable references of previous and current clients of corporate or public sector organizations that have been serviced within the last 10 years with reference to similar service offerings. (To be substantiated by reference letters showing the quality of work rendered as well as a list of successfully completed projects including value). • Five (5) Projects (50 points) • Four (4) Project (40 points) • Three (3) Projects (30 points) • Two (2) Projects (20 points) • One (1) Project (10 points)
<p>2. Technical Approach</p>	<p>Bidders to submit a three (3) years maintenance plan and must entail but not limited to the following:</p> <ul style="list-style-type: none"> • communication plans, • Service intervals, • Emergency response time, • Risk management plan • measures that will be put in place to minimize constant faults on machines.
<p>3. Capability</p>	<p>The company must have resources with the relevant and appropriate experience and skills and provide the following:</p> <ul style="list-style-type: none"> • The bidder must provide CV/s with relevant certified accreditation to install X-ray machines for all technical Personnel who will be working on this project. • Three (3) technician and above (30 points) • Two (2) technician (20 points) • One (1) technician (10 points)
<p>NB: Minimum 70% qualifications on functionality.</p>	

G.D.N



independent police investigative directorate

Department:
Independent Police Investigative Directorate
REPUBLIC OF SOUTH AFRICA

NB. Bidders that score 70 points or more in respect of functional and technical aspect will be further evaluated on price and (HDI POINTS). Bidders who scored less than 70 will be regarded as non – responsive bid and will be disqualified.

9.3 Phase 3 - Price and HDI points

A detailed and complete cost break down **must** be provided by completing the pricing schedule (**Annexure A**), and the total bid price must be indicated on the Pricing Schedule (SBD 3.1).

Bids will be evaluated in terms of the Preferential Procurement Points system where the **80/20** Preference point system will be used. The preferential procurement points will account for 80 points on pricing and the Historical Disadvantaged Individuals (HDI) points will be added to points for pricing.

PREFERENTIAL POINTS

This bid is anticipated not to exceed R50 million and therefore, the 80/20 preferential point system for acquisition of goods and services with Rand value above R30 000.00 and up to R50 million will apply.

The following formula must be used to calculate the points out of 80 for price in respect of an invitation for tender with a Rand value above R30 000.00 and up to R50 million, inclusive of all applicable taxes.

The points obtained will then be converted to 80% of the total points as follows:

$$P_s = 80 \left(1 - \frac{P_t - P_{min}}{P_{min}} \right)$$

Where

P_s = Points scored for price of the bid under consideration

P_t = Rand value of the bid under consideration

P_{min} = Rand value of lowest responsive bid

A maximum of 20 points may be awarded to a tender for specific goals specified for the tender as follows:

Specific goals	Points
Historically Disadvantaged Individuals (HDI)	
Enterprises with ownership of 51% or more by person/s who are black	8
Enterprises with ownership of 51% or more by person/s who are women	8

7 | Page

SPECIFICATION FOR X-RAY MACHINES AND MAINTENANCE

G.J.M.



independent police investigative directorate

Department
Independent Police Investigative Directorate
REPUBLIC OF SOUTH AFRICA

Enterprises with ownership of 51% or more by person/s who are youth	2
Enterprises with ownership of 51% or more by person/s with disability	2
Total	20

The points scored for specific goal must be added to the points scored for price and the total must be rounded off to the nearest two decimal places.

The contract/ order must be awarded to the tenderer scoring the highest points.

If two or more tenders score an equal total number of points, the contract must be awarded to the tenderer that scored the highest points for specific goals, and if two or more tenders score total equal points in all respects, the award must be decided by drawing of lots

Regulations.

11.4 The bidder who scored the highest points will be recommended for the bid.

Failure to capture the required status and to submit the required HDI.

- (a) The points scored by a bidder in respect of points indicated above will be added to the points scored for price.
- (b) Bidders are requested to complete the various preference claim forms in order to claim preference points.
- (c) Only a bidder who has completed and signed the declaration part of the preference claim form will be considered for HDI status.
- (d) Points scored will be rounded off to the nearest 2 decimals.
- (e) In the event that two or more bids have scored equal total points, the contract will be awarded to the bidder scoring the highest number of points for HDI status. Should two or more bids be equal in all respects, the award shall be decided by drawing of lots.
- (f) A contract may, on reasonable and justifiable grounds, be awarded to a bid that did not score the highest number of points.



independent police investigative directorate

Department
Independent Police Investigative Directorate
REPUBLIC OF SOUTH AFRICA

5. BID CONDITIONS

- a) Security screening in respect of the preferred company and the Director(s) of the company shall be conducted and they will be required to sign oath of secrecy upon assumption of duty. Appointment of preferred Bidder will be done subject to positive security screening results.
- b) The installation described in this document shall comply with the various standard specification requirements as well as this specification.
- c) The floor layout showing the scope and extent of the proposed work, as well as the general layout required for the security, installation enrollment office and take-on station will be provided to the successful Bidder.
- d) The successful Bidder must be able to supply and install the required security system within two (2) months after awarding.
- e) The work at all times, for the duration of the contract, must be carried out under the supervision of a skilled and competent representative of the contractor, who must be able and authorized to receive and carry out instructions on behalf of the contractor.
- f) All equipment's, must comply with the films safety ISO1600 and shall be Y2K compliant. All cabling and wiring required by the security equipment's or system must be installed in dedicated sleeves, conduits, cable trays or raceways.
- g) After completion of the installation at the location, a full test will be carried out on the installation for a period of five (5) working days to determine the satisfactory working thereof. During this period the installation will be inspected to the satisfaction of the Department and the service provider shall submit a report on any defects which may arise.
- h) The service provider shall provide all instruments and equipment required for testing the machines.
- i) Test reports as specified under (a) is to be submitted to the Department.



independent police investigative directorate

Department:
Independent Police Investigative Directorate
REPUBLIC OF SOUTH AFRICA

6. Enquiries

Enquiries may be directed to the following persons:

FOR BID ADMINISTRATION
Mr Mteteleli Gqalane / Ms. Fikile Maseko
Tel: (012) 399 0103/0095
Email: mgqalane@ipid.gov.za/fmaseko@ipid.gov.za
FOR TECHNICAL ENQUIRIES
Mr T C Mathivha
Tel: (012) 399 0060
Email: Tmathivha@ipid.gov.za

G.S.M.